

Industrial Economy Cartridge Filter Housing

5 Round

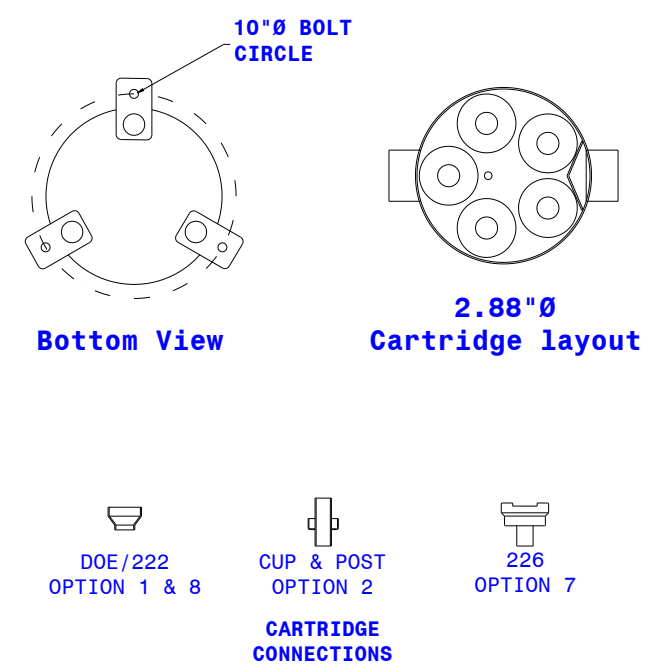
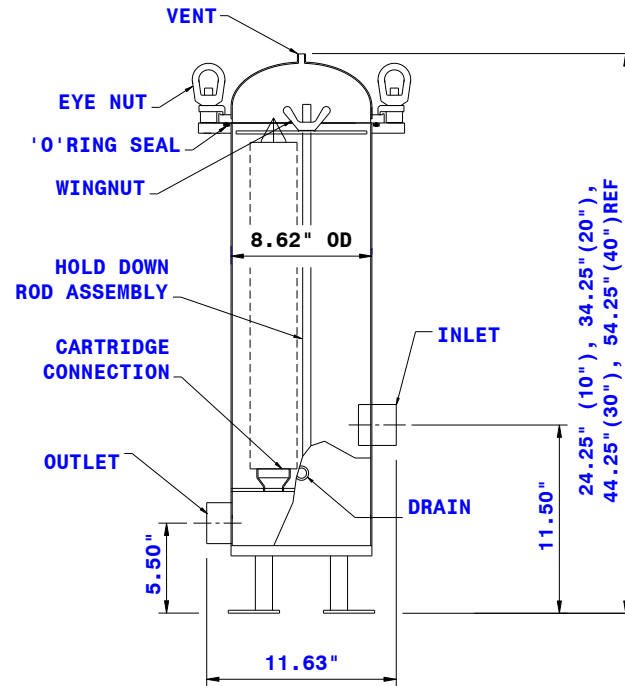
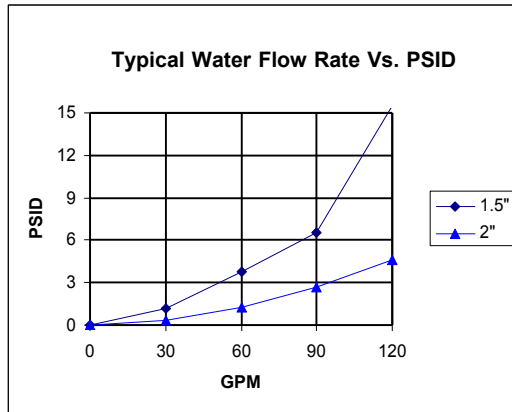

Housing Part Number

Note: Dimensions are for reference only. Design drawings available upon request.

Industrial Economy	5 Round	Element Length	Cartridge Connection	Inlet/Outlet Size	Inlet/Outlet Connection	Vent/Drain Connection	Gasket Material	Interior/Exterior Finish
IE	- 5	-	-	-	-	-	-	-
1	10"	1	DOE	1.5"	TC TriClamp	TC 1/2" TriClamp	E EPDM	BBP Bead Blast & Passivate
2	20"	2	Cup & Post	2"	F Flanged	N 1/2" FNPT		
3	30"	7	226		N FNPT	V 1/4" Valve		EP Electropolish
4	40"	8	222					