

Industrial High Purity Cartridge Filter Housing

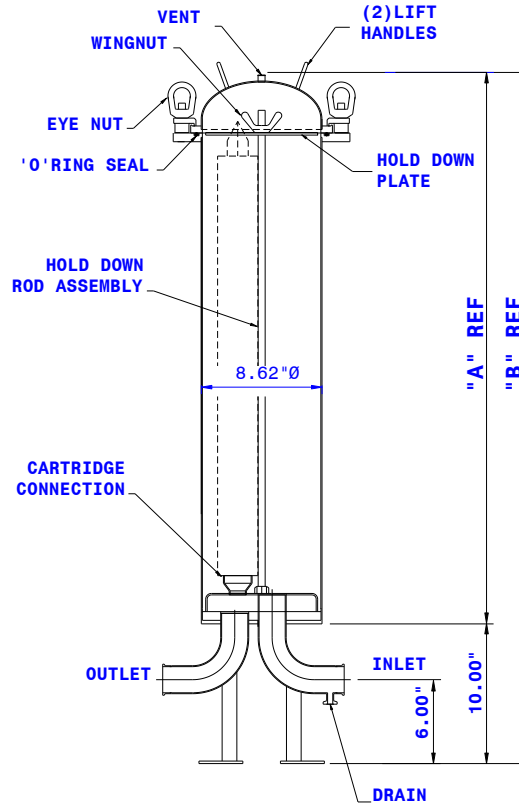

T- Style, 5 Round (Top Open)



Element Length	A	B	C
10"	18.25"	28.50"	13.00"
20"	28.25"	38.50"	13.00"
30"	38.25"	48.50"	13.00"
40"	48.25"	58.50"	13.00"

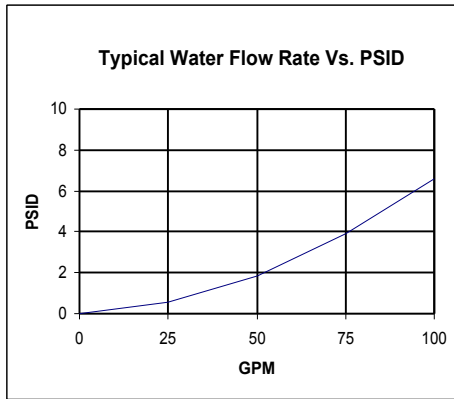
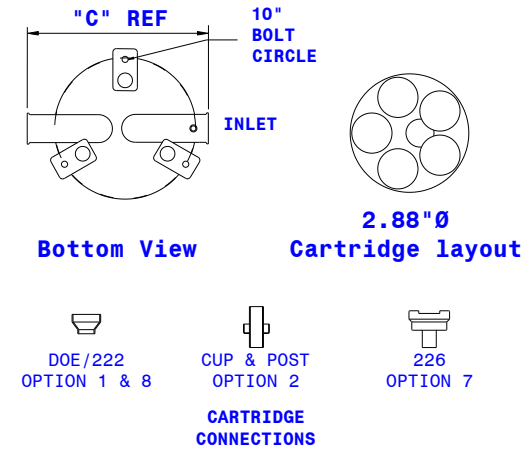

Custom Housing Part Number

Note: Dimensions are for reference only. Design drawings available upon request

IHP Industrial High Purity	- 5TT 5 Round T-style T Top Open	- _ Element Length	- _ Cartridge Connection	- 2 _ Inlet/Outlet Connection	- 1/2 _ Vent/Drain Connection	- _ Gasket Material	- _ Interior/Exterior Finish
		1 10"	1 DOE	TC Tri Clamp	TC Tri Clamp	E EPDM	BBP Bead Blast
		2 20"	2 Cup & Post	F Flanged	NPT Female Threaded	V Viton	& Passivate
		3 30"	7 226			S Silicon	EP Electropolish
		4 40"	8 222				