

# Industrial High Purity Cartridge Filter Housing

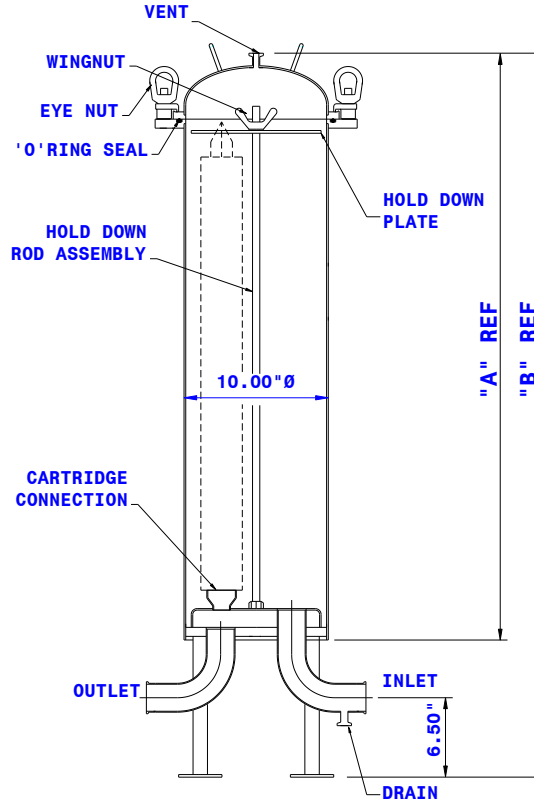

## T- Style, 7 Round (Top Open)

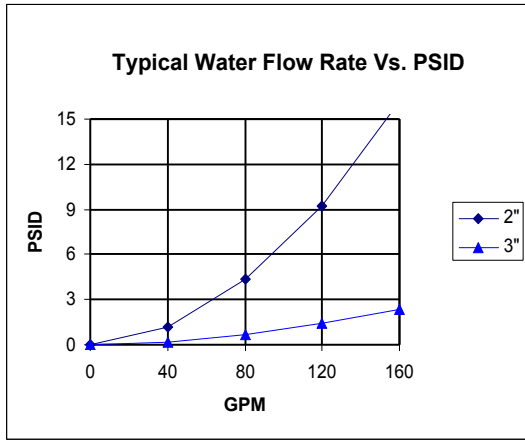

Element Length	A	B	C 2" I/O	C 3" I/O
10"	19.50"	31.75"	15.13"	18.13"
20"	29.50"	41.75"	15.13"	18.13"
30"	39.50"	51.75"	15.13"	18.13"
40"	49.50"	61.75"	15.13"	18.13"

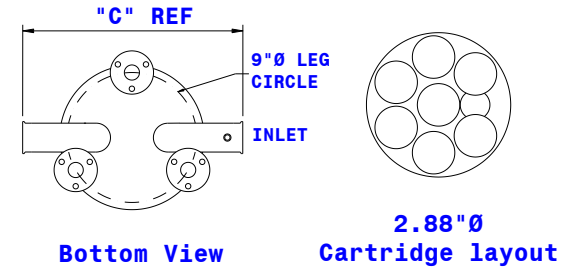

## Custom Housing Part Number

Note: Dimensions are for reference only. Design drawings available upon request

IHP	- 7TT	- ___	- ___	- ___	- 1/2 ___	- ___	- ___
Industrial High Purity	7 Round T-style	Element Length	Cartridge Connection	Inlet/Outlet Connection	Vent/Drain Connection	Gasket Material	Interior/Exterior Finish
	T Top Open	1 10"	1 DOE	2" TC Tri Clamp	TC Tri Clamp	E EPDM	BBP Bead Blast & Passivate
		2 20"	2 Cup & Post	2" F Flanged	NPT Female Threaded	V Viton	
		3 30"	7 226	3" TC Tri Clamp		S Silicon	EP Electropolish
		4 40"	8 222	3" F Flanged			