

# Industrial High Purity Cartridge Filter Housing

## T- Style, 12 Round (Top Open)

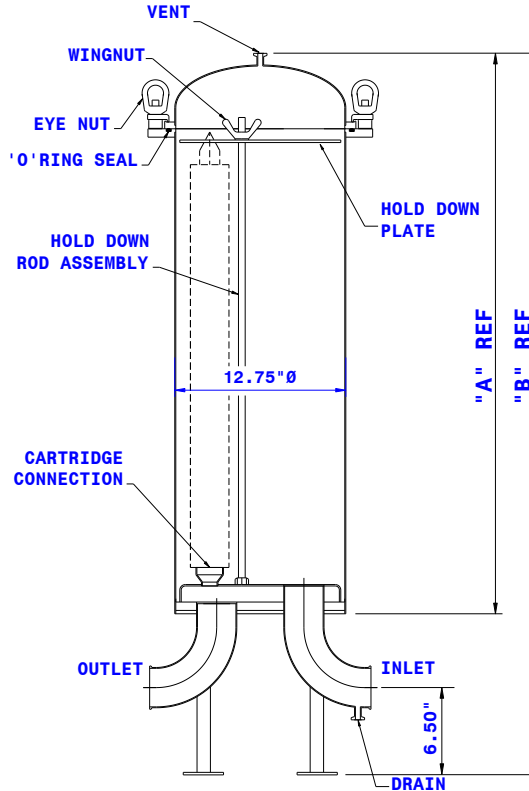

Element Length	A	B	C 3" I/O	C 4" I/O
10"	21.50"	33.75"	19.75"	23.31"
20"	31.50"	43.75"	19.75"	23.31"
30"	41.50"	53.75"	19.75"	23.31"
40"	51.50"	63.75"	19.75"	23.31"

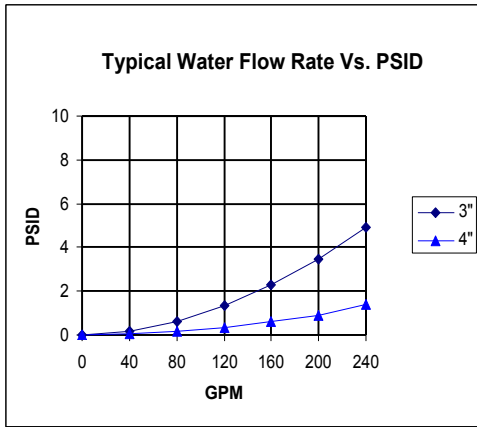
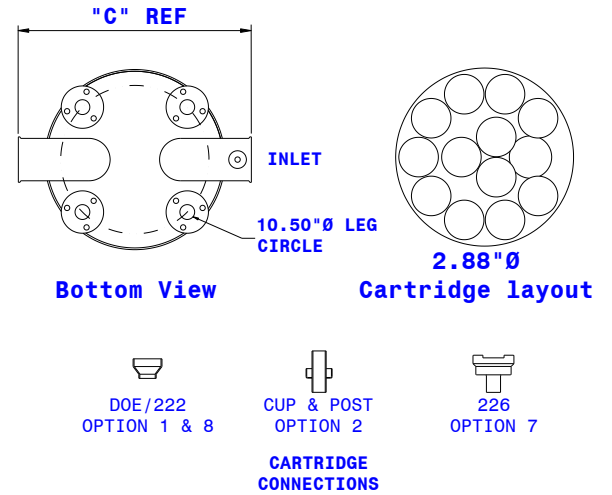

## Custom Housing Part Number

Note: Dimensions are for reference only. Design drawings available upon request.

IHP Industrial High Purity	- 12TT 12 Round T-style 12 Top Open	- ____ Element Length	- ____ Cartridge Connection	- ____ Inlet/Outlet Connection	- 1/2 ____ Vent/Drain Connection	- ____ Gasket Material	- ____ Interior/Exterior Finish
		1 10"	1 DOE	3" TC Tri Clamp	TC Tri Clamp	E EPDM	BBP Bead Blast
		2 20"	2 Cup & Post	3" F Flanged	NPT Female Threaded	V Viton	& Passivate
		3 30"	7 226	4" TC Tri Clamp		S Silicon	EP Electropolish
		4 40"	8 222	4" F Flanged			