

Industrial High Purity Cartridge Filter Housing

22 Round Offset

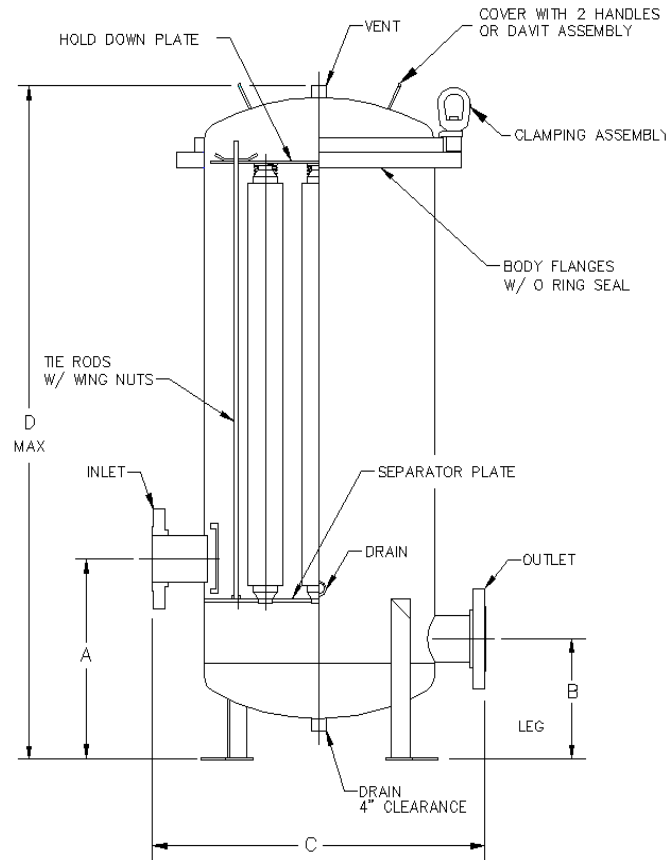
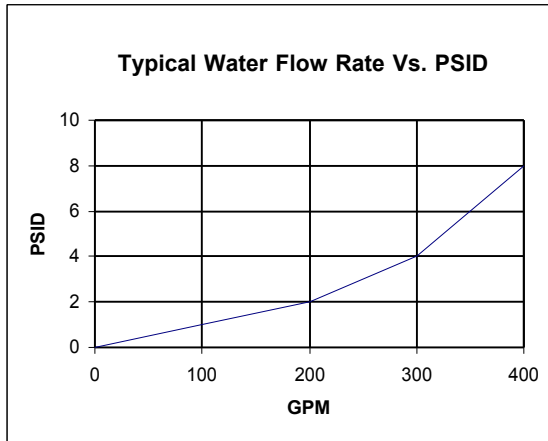

DIMENSIONAL DATA

| CARTRIDGE LENGTH | CONNECTION TYPE | "A" | "B" | "C" | "D" | WT. (LBS) |
|------------------|-----------------|---------|---------|-----|---------|-----------|
| 30" | 3" & 8/4" F | 17 1/2" | 11 1/2" | 26" | 53 1/2" | 185 |
| 30" | 3" TC | 17 1/2" | 11 1/2" | 22" | 53 1/2" | 160 |
| 30" | 4" TC | 17 1/2" | 11 1/2" | 21" | 53 1/2" | 165 |
| 40" | 3" & 8/4" F | 17 1/2" | 11 1/2" | 26" | 63 1/2" | 195 |
| 40" | 3" TC | 17 1/2" | 11 1/2" | 22" | 63 1/2" | 170 |
| 40" | 4" TC | 17 1/2" | 11 1/2" | 21" | 63 1/2" | 175 |

MAXIMUM FILTER DIAMETER 2 3/4"



CARTRIDGE CONNECTIONS

Custom Housing Part Number

Note: Dimensions are for reference only. Design drawings available upon request.

| IHP Industrial High Purity | - 22OT 22 Round Offset Style | - ___ Element Length | - ___ Cartridge Connection | - ___ Inlet/Outlet Connection | - 1/2 ___ Vent/Drain Connection | - ___ Gasket Material | - ___ Interior/Exterior Finish |
|-------------------------------|---------------------------------|-------------------------|-------------------------------|----------------------------------|------------------------------------|--------------------------|-----------------------------------|
| | | 3 30" | 1 DOE | 3TC Tri Clamp | TC Tri Clamp | E EPDM | BBP Bead Blast |
| | | 4 40" | 2 Cup & Post | 3F Flanged | NPT Female Threaded | V Viton | & Passivate |
| | | | 7 226 | 4TC Tri Clamp | | S Silicon | EP Electropolish |
| | | | 8 222 | 4F Flanged | | | |